

**roypasa**

CENTRO DE PRODUÇÃO DE PVC E ALUMÍNIO

# MOLDURA



**PM1001** 2.V



**PM1001** 1.V



**PM1001**



**PM1002** 2.V



**PM1002**



**PM1003** 1.V

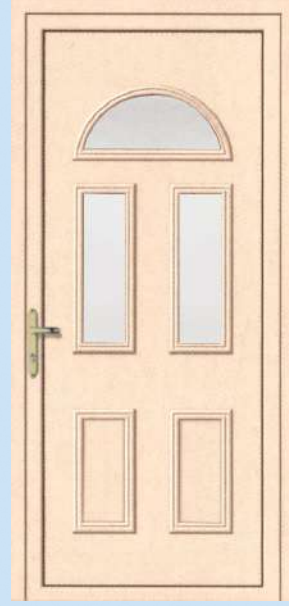

**PM1003** 3.V



**PM1003** 5.V



**PM1003**



**PM1004** 2.V



**PM1004**



**PM1009** 1.V



**PM1009**



**PM1011 2.V**



**PM1011 4.V**



**PM1011**



**PM1012 1.V**



**PM1012**



**PM1013 3.V**



**PM1013**



**PM1014 1.V**

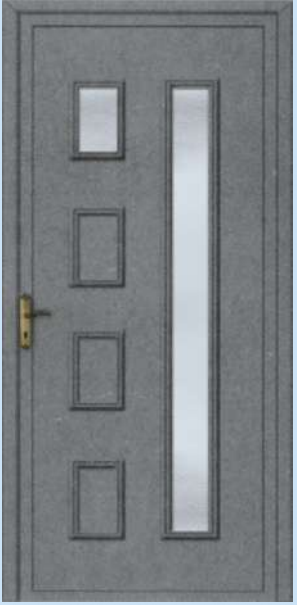

**PM1015** 2.V



**PM1015** 1.VL



**PM1015** 4.V



**PM1015** 5.V

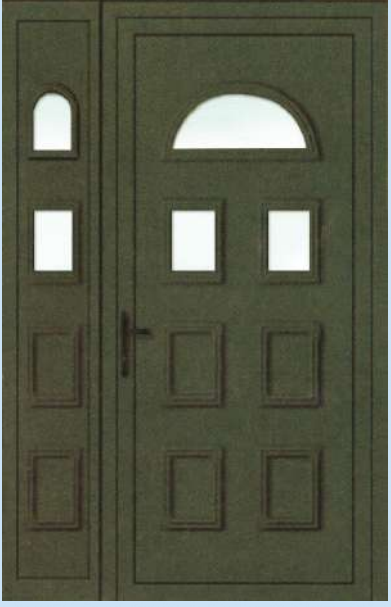

**PM1014** 3.V



**PM1014** 5.V



**PM1014** 7.V



**PM1014**



**PM1015**



**PM1016**



**PM1016 3.V**



**PM1016 4.V**



**PM1016 1.V**



**PM1018 1.V**



**PM1018**



**PM1019 5.V**



**PM1019**



**PM1023 1.V**



**PM1023** 2.V



**PM1023**



**PM1024** 2.V



**PM1024** 3.V



**PM1024**



**PM1025** 2.V



**PM1025** 4.V



**PM1025** 6.V



**PM1025** 8.V



**PM1025**



**PM1029** 2.V



**PM1029** 4.V



**PM1029**



**PM1030** 1.V



**PM1030**



**PM1028** 3.V



**PM1028** 2.V



**PM1028** 1.V



**PM1028**



**PM1029** 6.V



**PM1032**



**PM1031**



**PM1031 2.V**



**PM1031 4.V**



**PM1031 6.V**



**PM1032 1.V**

# ESTAMPADAS



**ST2001 1.V**



**ST2001**



**ST2002 3.V**



**ST2002 1.V**



**ST2002 2.V**



**ST2003** 2.V



**ST2003**



**ST2003** IVL



**ST2003** CLAVOS



**ST2003** 3.R



**ST2003** 1.VRC



**ST2003** 2.R



**ST2003** I.V



**ST2004** 1.V



**ST2003** 4.R CLAVOS



**ST2005**



**ST2003** 4.R



**ST2005** CLAVOS



**ST2004**



**ST2005** 1.V



**ST2004** CLAVOS



**ST2005** 2.R 1.V



**ST2005** 2.V



**ST2005** 3.R



**ST2005** R.200



**ST2005** 3.R 1.V



**ST2005** R.200 1.V



**ST2005** 4.R



**ST2005** 2.R



**ST2005** 3.X 2.R 1.V



**ST2005** 4.R 1.V



**ST2006**

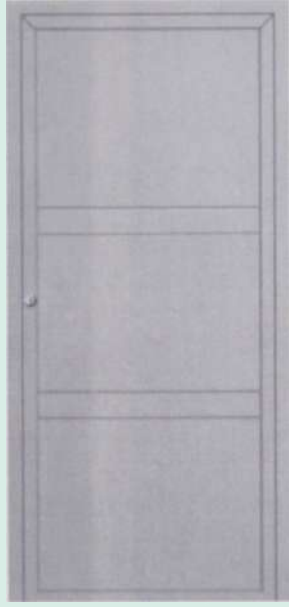

**ST2005** 2.X 2.R



**ST2006** CLAVOS

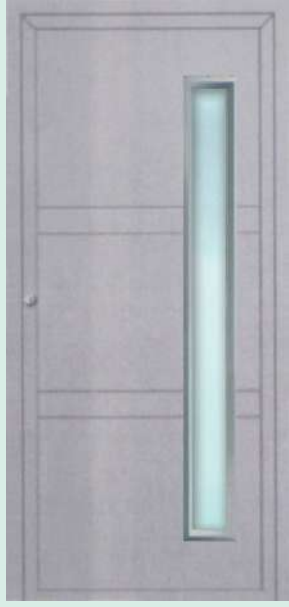

**ST2005** 2.X 2.R 1.V



**ST2006** 2.VGC



**ST2005** 3.X 2.R



**ST2008**



**ST2006** 2.VPC



**ST2008** 1.V



**ST2007**



**ST2008** 3.V



**ST2007** CLAVOS



**ST2009**



**ST2007** 2.VC



**ST2009** 1.V



**ST2010**



**ST2010** 1.V



**ST2011**



**ST2011** 1.V



**ST2012**



**ST2012** 1.V



**ST2015**



**ST2015** 1.V



**ST2016**



**ST2016** 2.V



**ST2016** 4.V



**ST2017**



**ST2017** 2.V



**ST2018**



**ST2018** 2.V



**ST2018** 4.V



**ST2019**



**ST2019** 2.V



**ST2020**



**ST2020** 1.V



**ST2020** 3.V



**ST20120** 5.V



**ST2020** 7.V



**ST2021**



**ST2021** 3.V



**ST2023**



**ST2023** 1.V

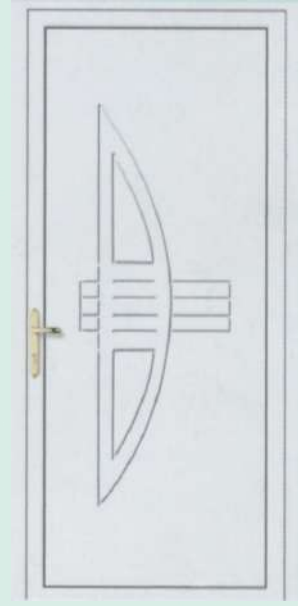

**ST2024**



**ST2024** 2.V

# INOX



**NX3002**



**NX3003**



**NX3001 S. INOX**

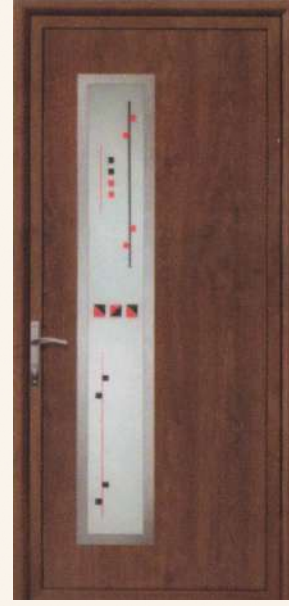

**NX3004 C. INOX**



**NX3001 C. INOX**



**NX3007** 2.V



**NX3004** S. INOX



**NX3007**

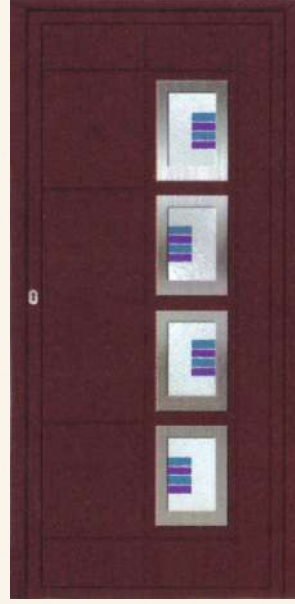

**NX3005** 4.V



**NX3008** C. INOX 1.V

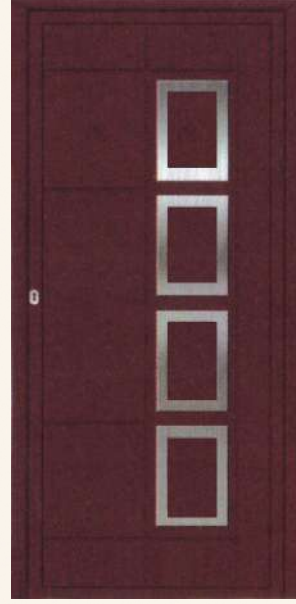

**NX3005**



**NX3008** S. INOX 1.V



**NX3006**



**NX3011** 3.V



**NX3008** C. INOX



**NX3011**



**NX3009**



**NX3012**



**NX3010** 4.V



**NX3013**



**NX3010**



**NX3014** 1.V



**NX3015** 4.V



**NX3015**



**NX3016**



**NX3017**



**NX3018**



**NX3019**



**NX3020**



**NX3021**



**NX3022**



**NX3027**



**NX3023**



**NX3028**



**NX3024**



**NX3029**



**NX3025**



**NX3030** S. INOX 1.V



**NX3026** C. INOX 1.V



**NX3030** C. INOX 1.V



**NX3026** S. INOX 1.V



**NX3033** S. INOX 1.V



**NX3030** C. INOX R.1.V



**NX3033** C. INOX 6.V



**NX3030** S. INOX R.1.V



**NX3034**



**NX3032**



**NX3035**



**NX30323** C. INOX 1.V



**NX3039**



**NX3036**



**NX3041**



**NX3037**



**NX3042**



**NX3038 S. INOX 6.V**



**NX3043**



**NX3038 C. INOX 6.V**



**NX3047** C. INOX 1.V



**NX3044**



**NX3047**



**NX3045**

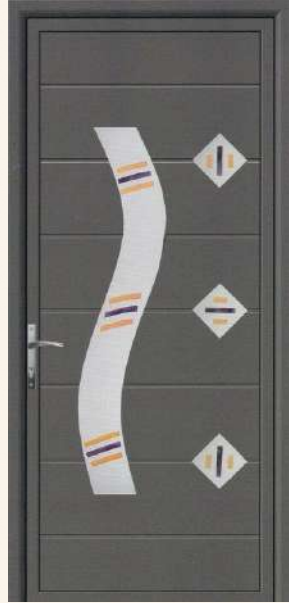

**NX3048** S. INOX 4.V



**NX3046** S. INOX 3.V



**NX3048** C. INOX 4.V



**NX3046** C. INOX 3.V

# ACESSÓRIOS

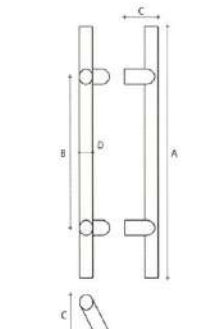
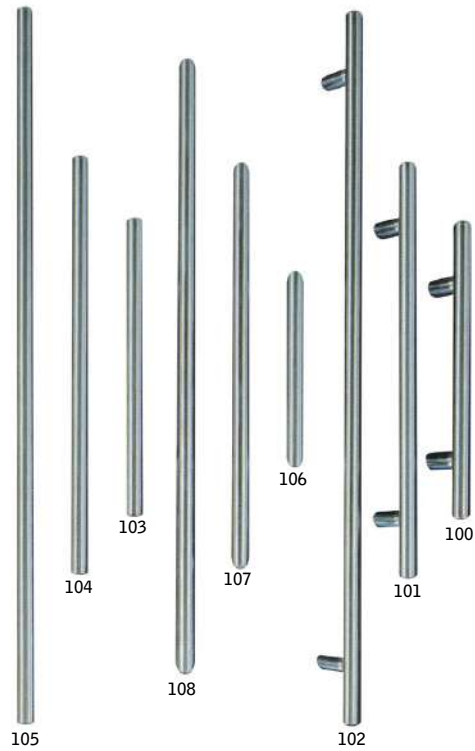

	A	B	C	D
<b>100</b>	500	300	97	32
<b>101</b>	700	500	97	32
<b>102</b>	1200	1000	97	32

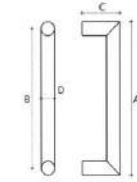

	A	B	C	D
<b>106</b>	330	300	85	30
<b>107</b>	680	650	85	30
<b>108</b>	103	1000	85	30

# INOX

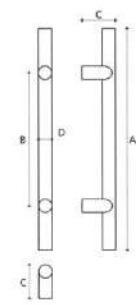

	A	B	C	D
<b>103</b>	500	300	87	32
<b>104</b>	700	500	87	32
<b>105</b>	1200	1000	87	32

# INOX

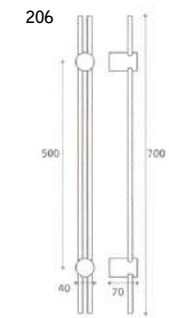
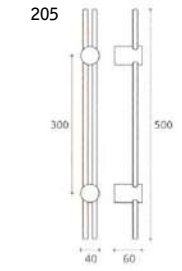
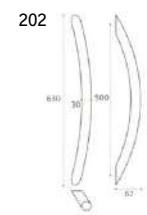
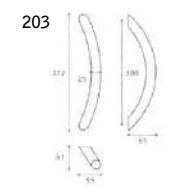
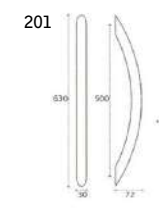
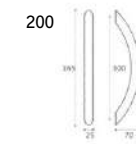
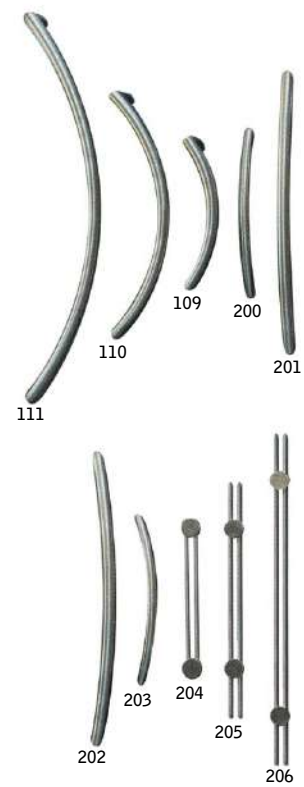

	A	B	C	D	E
<b>109</b>	330	300	85	30	76
<b>110</b>	530	500	85	30	131
<b>111</b>	800	770	85	30	121

# ALUMÍNIO / INOX

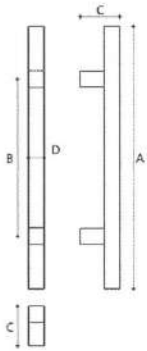
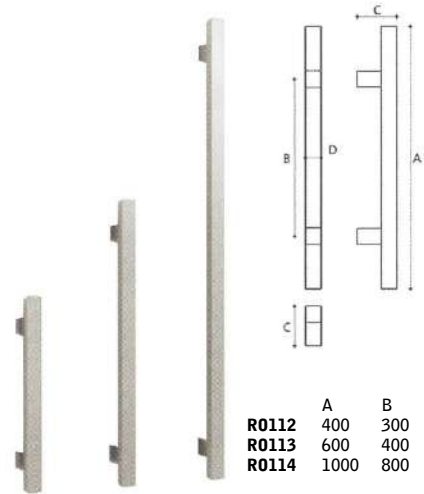

	A	B	C	D
<b>R0112</b>	400	300	75	30
<b>R0113</b>	600	400	75	30
<b>R0114</b>	1000	800	75	30

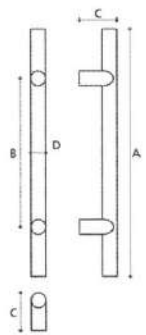
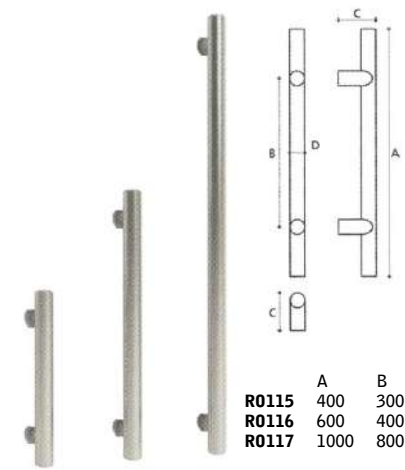

	A	B	C	D
<b>R0115</b>	400	300	75	30
<b>R0116</b>	600	400	75	30
<b>R0117</b>	1000	800	75	30

# ALUMÍNIO / INOX

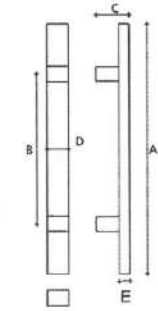

	A	B	C	D	E
<b>R0118</b>	400	300	75	40	20
<b>R0119</b>	600	400	75	40	20
<b>R0120</b>	1000	800	75	40	20

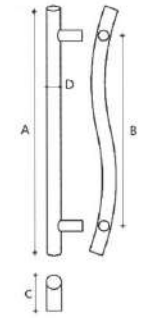
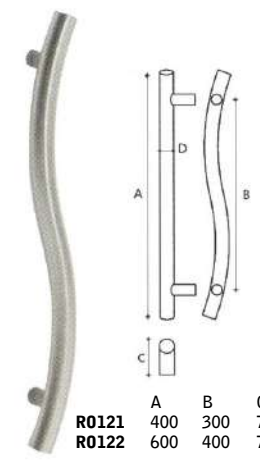

	A	B	C	D
<b>R0121</b>	400	300	75	30
<b>R0122</b>	600	400	75	30

---

**roypasa**

CENTRO DE PRODUÇÃO DE PVC E ALUMÍNIO

Rua de Espanha, 254  
Zona industrial da Lagoa, Lote D1  
4950-850 Cortes, Monção (Portugal)



Tel.: 00351 251 640 140

Fax: 00351 251 640 149

[pedidos@roypasa.net](mailto:pedidos@roypasa.net)



Mobil: 0034 626 799 737